

4. Electronic Tachometer With Operating Hours Counter (dia. 80 mm / dia.100 mm) only for VDO cockpit international

Contents	Page
4.1 General informations	4 - 2
4.2 Technical data	4 - 4
4.3 Pulsing	4 - 6
4.4 Wiring diagrams	4 - 7
4.5 Setting	4 - 9
4.6 Display	4 - 16
4.7 Testing instructions	4 - 17
4.8 Instruments survey	4 - 19
4.9 Installation instructions	4 - 20

4. Electronic Tachometer With Operating Hours Counter (dia. 80 mm / dia.100 mm) only for VDO cockpit international

4.1 General Informations

The electronic tachometer with operating hours counter has been designed for land-bound vehicles or stationary systems only (with the exception of motorcycles).

The instrument has an analog engine speed indication in RPM x 100 and a liquid crystal display for the operation hours count.

The electronic tachometer is pulsed by an inductive sensor or a generator sensor or by the terminal W of the alternator in the case of diesel engines, by terminal 1 of ignition coil in the case of petrol engines.

The instrument is set by a pushbutton at the back of the instrument.



The lamp sockets are clipped in.
To replace the light bulb, carefully, with the thumb, push the lamp holder out to the side.

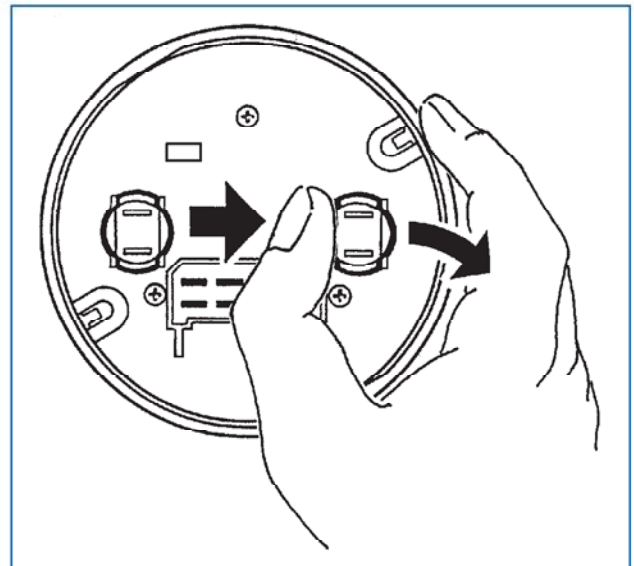

4. Electronic Tachometer With Operating Hours Counter (dia. 80 mm / dia.100 mm) only for VDO cockpit international

4.1 General Informations

Designation of function

Stepper motor movement

The drive for this display system is a stepper motor, comprising a permanent magnet rotor within a crossed winding arrangement. A zero backlash gearbox at the output ensures a high drive torque and fine resolution. The gearbox has a reduction ratio of 43.2 : 1 and an internal mechanical stop. The stepper motor drive was developed specially by VDO for this product.

The drive produces a bipolar sinusoidal variable voltage using digital pulse width modulation. There is a 90° phase difference (sine-cosine) between the voltages on the two motor coils. This rotates the electromagnetic field through equidistant angular steps with a constant length resultant vector ($\sin^2\theta + \cos^2\theta = 1$).

The motor torque is therefore constant at each step with zero cogging. At the pointer one motor step equals 0.065°.

The stepper motor parameters and the design of VDO control-driver electronics are carefully matched to ensure reliable operation of the system under all conditions. Optimised control algorithms ensure a visually smooth pointer motion.

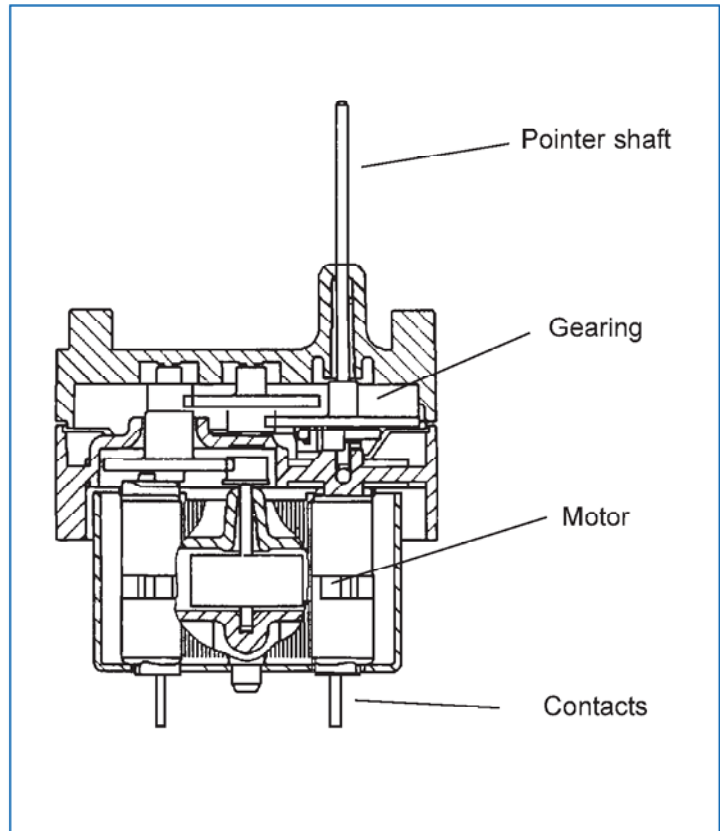

4. Electronic Tachometer With Operating Hours Counter (dia. 80 mm / dia.100 mm) only for VDO cockpit international

4.2 Technical Data

Operating voltage:	10 ... 31 V
Input voltage:	U_{low} : 0 V U_{high} : min. 1 V
Movement:	Stepper motor
Pickup:	Terminal 1 ignition coil (petrol engine) or Terminal W alternator (diesel engine) Inductive sensor or Generator sensor
Current consumption:	< 100 mA (120 mA with illumination) < 0,1 mA standby
Operating temp.:	-20°C ... +70°C
Storage temperature:	-30°C ... +85°C
Illumination:	2 light bulbs, 12 V, 2 W or 24 V, 2 W
Protection:	IP64 DIN 40050 from the front Housing 'ozon'-proof, 'UV'-proof CE approved, reverse-polarity protection
Vibration resistance:	max. 1g eff., 25 ... 500 Hz, duration 8h, f: 1 octave/min.
Nominal position:	NL 0 to NL 90, DIN 16257

VDO cockpit international
dia. 80 mm Floodlight



Operating hours counter: 999999.9h

Mounting hole: dia. 81mm

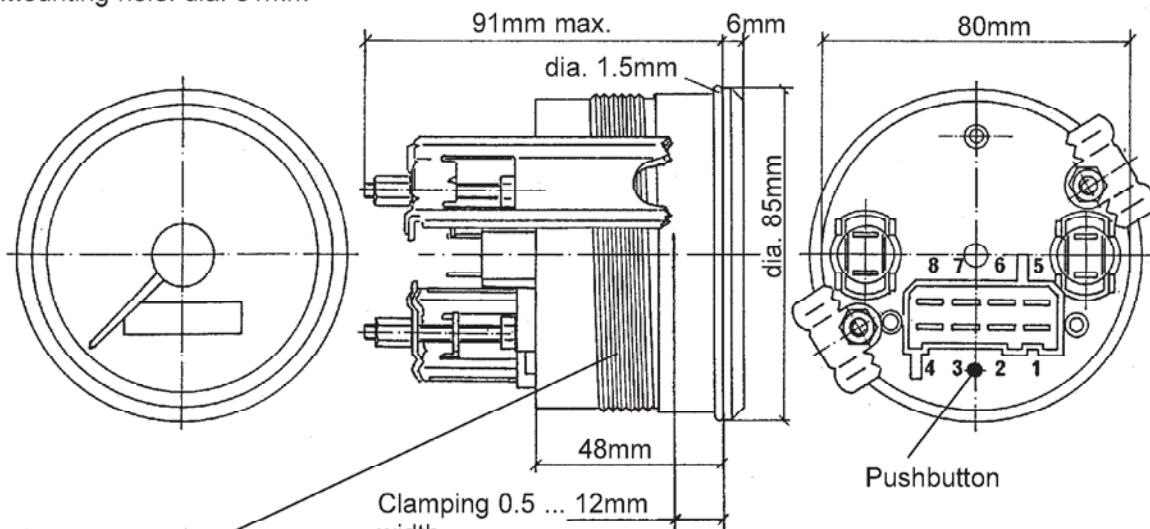

Thread for clamp ring
(clamping width 0.5 ... 12mm
or 12 ... 23mm)

0.5 ... 399.99 pulses / revolution
(adjustable)

* Not available on some instruments.

Pin assignment:

- Pin 3: ground, terminal 31
- Pin 4: + 12 V or + 24 V, terminal 15
- Pin 5*: permanent positive pole 12 V / 24 V,
terminal 30
- Pin 7: signal input
inductive sensor, generator sensor
(2 signal wires)
- Pin 8: terminal 1 or W (1 signal wire)
or inductive sensor, generator sensor
(2 signal wires)

4. Electronic Tachometer With Operating Hours Counter (dia. 80 mm / dia.100 mm) only for VDO cockpit international

4.2 Technical Data

Operating voltage:	10 ... 31 V
Input voltage:	U_{low} : 0 V U_{high} : min. 1 V
Movement:	Stepper motor
Pickup:	Terminal 1 ignition coil (petrol engine) or Terminal W alternator (diesel engine) Inductive sensor or Generator sensor
Current consumption:	< 100 mA (120 mA with illumination) < 0.1 mA standby
Operating temp.:	-20°C ... +70°C
Storage temperature:	-30°C ... +85°C
Illumination:	2 light bulbs, 12 V, 2 W or 24 V, 2 W
Protection:	IP64 DIN 40050 from the front Housing 'ozon'-proof, 'UV'-proof CE approved, reverse-polarity protection
Vibration resistance:	max. 1g eff., 25 ... 500 Hz, duration 8h, f: 1 octave/min.
Nominal position:	NL 0 to NL 90, DIN 16257

VDO cockpit international
dia. 100 mm Floodlight

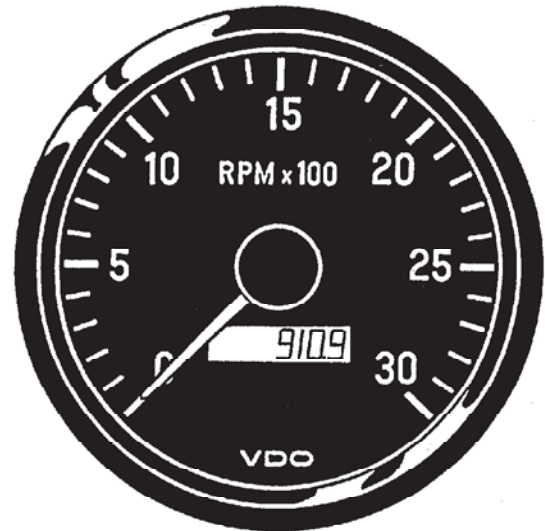

Operating hours counter: 999999.9 h

Mounting hole: dia.101mm

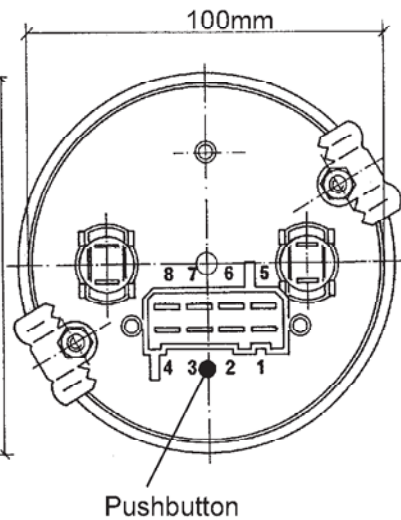
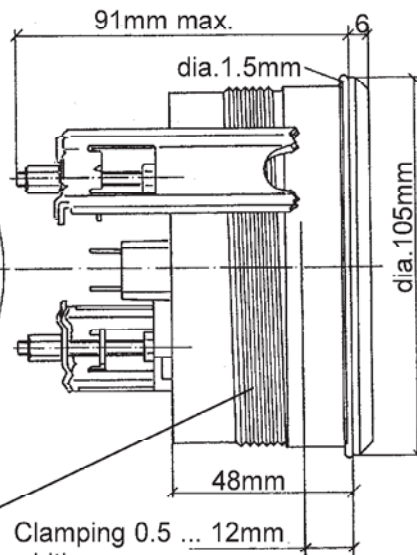
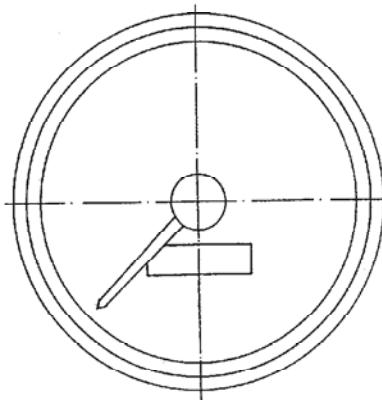

Thread for clamp ring
(clamping width 0.5 ... 12mm
or 12 ... 23mm)

0.5 ... 399.99 pulses /revolution
(adjustable)

* Not available on some instruments.

Pin assignment:

- Pin 3: ground, terminal 31
- Pin 4: + 12 V or + 24 V, terminal 15
- Pin 5*: permanent positive pole 12 V / 24 V,
terminal 30
- Pin 7: signal input
inductive sensor, generator sensor
(2 signal wires)
- Pin 8: terminal 1 or W (1 signal wire)
or inductive sensor, generator sensor
(2 signal wires)

4. Electronic Tachometer With Operating Hours Counter (dia. 80 mm / dia.100 mm) only for VDO cockpit international

4.3 Pulsing

The sensor needed for the pulsing of the tachometer with operating hours counter is not included in the shipment. The following sensors (see data sheets for sensors) can be used:

Inductive sensor

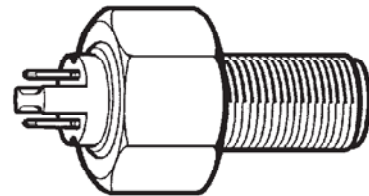

Tachometer connections: pin 7 and pin 8

Generator sensor

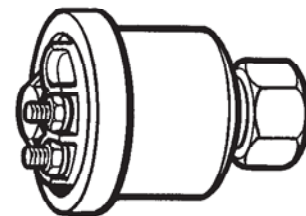

The pulsing can also be obtained from:

- Terminal W of the alternator of diesel-engine equipped vehicles.

Alternator

Tachometer connection pin 8

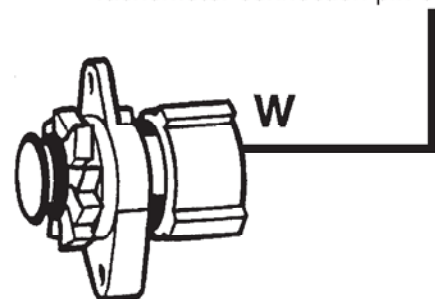

- Terminal 1 of the ignition coil in the case of conventional ignition systems (with one or more ignition coils), or a special terminal for special ignition systems of petrol engines. In the case of special ignition systems (such as transistor-coil ignitions, electronic and fully electronic ignition systems) please ask the vehicle manufacturer or the ignition system manufacturer for the correct terminal.

Conventional ignition system

Tachometer connection pin 8

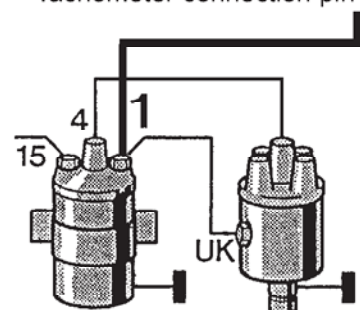

Ignition must be off and minus battery connection disconnected when connecting the cable.

4. Electronic Tachometer With Operating Hours Counter (dia. 80 mm / dia.100 mm) only for VDO cockpit international

4.4 Wiring Diagrams

Inductive sensor (2 signal wires)

Note:



Pin 5 is not available on instruments produced before week 18/99.

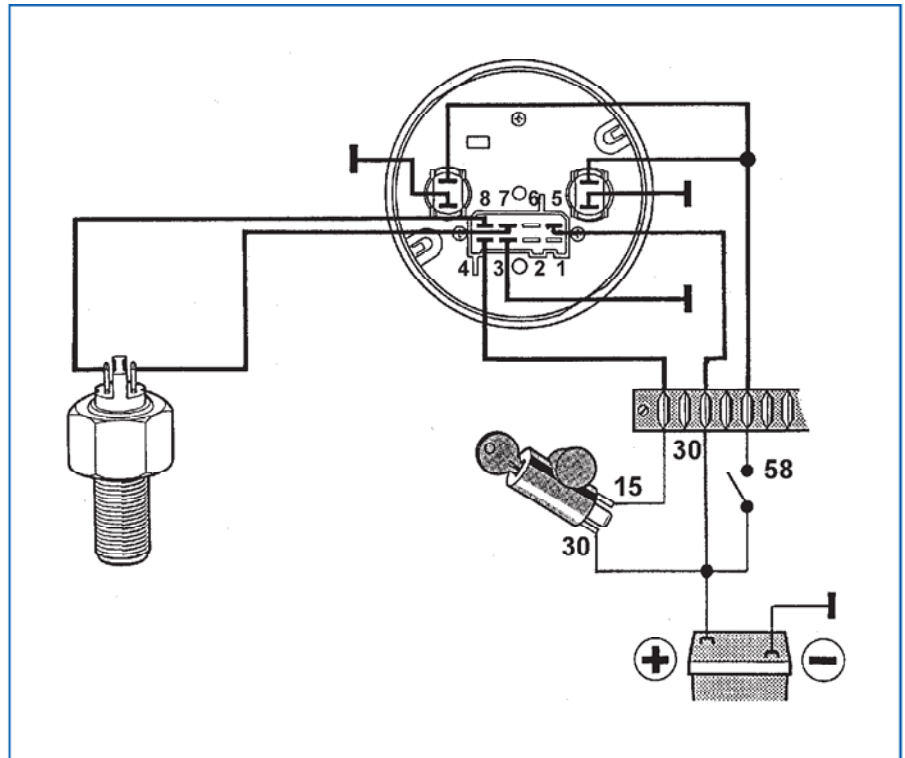

Generator sensor (2 signal wires)

Note:



Pin 5 is not available on instruments produced before week 18/99.

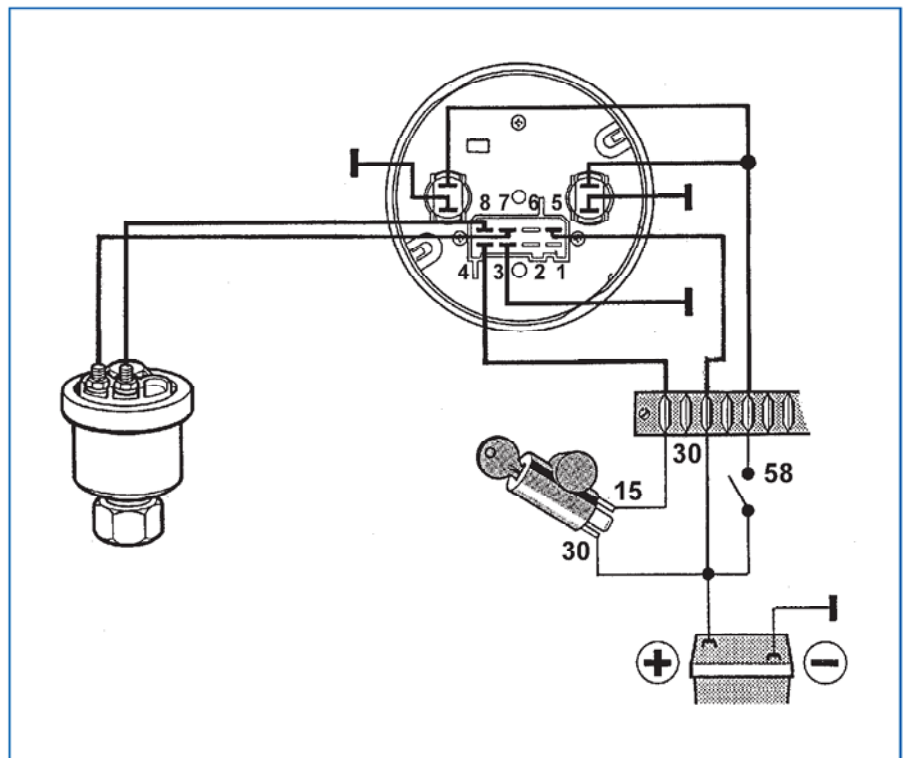

4. Electronic Tachometer With Operating Hours Counter (dia. 80 mm / dia.100 mm) only for VDO cockpit international

4.5 Setting

Four possible settings are available for the electronic tachometer with operating hours counter.

Two possible calibrations:

Function 'SELECT' - Enter the stroke number and the number of cylinders for vehicles with petrol engine (two-stroke or four-stroke) when connecting to terminal 1 of the ignition coil (ignition systems having only one ignition coil).



Not apply for vehicles with diesel engine.

Function 'PULSE' - Enter a know number of pulses per revolution for:

inductive sensor,

generator sensor,

connection to terminal W of the alternator on vehicles with diesel engines,

connection to terminal 1 of ignition coil (ignition systems having one or more ignition coils) for vehicles with petrol engine (two-stroke or four-stroke).

Two possible fine adjustments of the engine speed indication:

Function 'AdJUST' - Fine adjustment of engine speed indication (continuous pointer adjustment)

or

Function 'A' - Fine adjustment of engine speed indication (pointer adjustment in percentage steps).

4. Electronic Tachometer With Operating Hours Counter (dia. 80 mm / dia.100 mm) only for VDO cockpit international

4.5 Setting

Selection of the functions: 'SELECT', 'PULSE' or 'AdJUST'

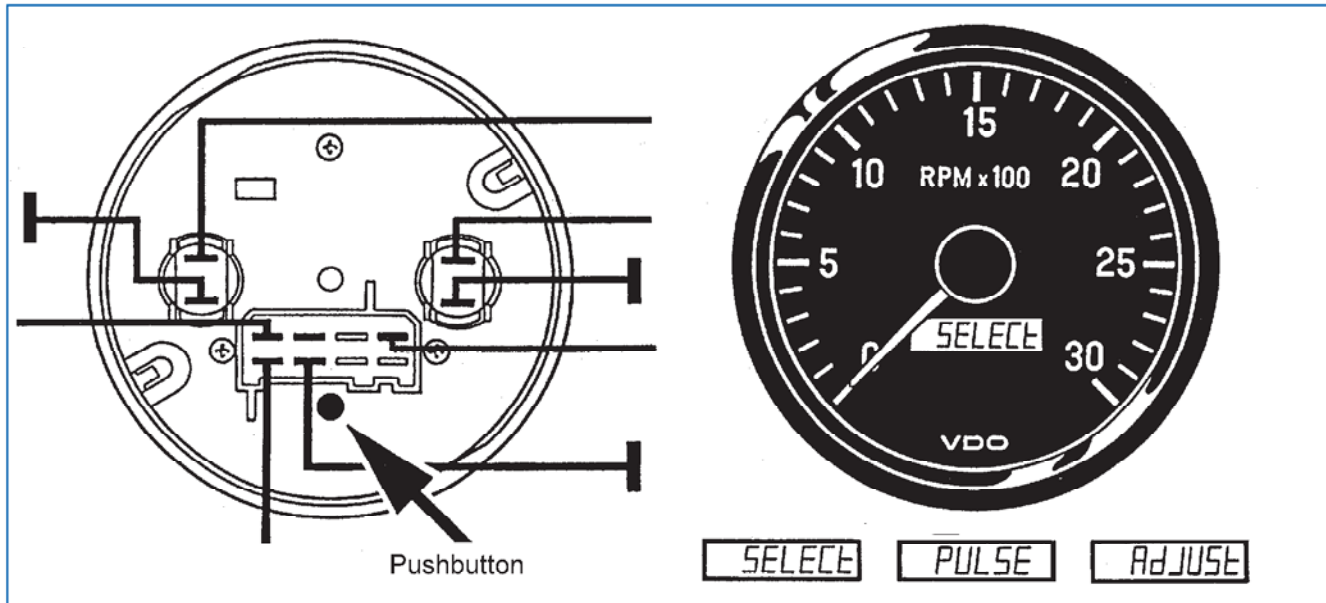

Push the button on the back of the instrument and hold, then switch the ignition on. The display alternates between 'SELECT', 'PULSE' and 'AdJUST'. A function is selected by releasing the pushbutton at the corresponding display.

Selection of the function: 'A'

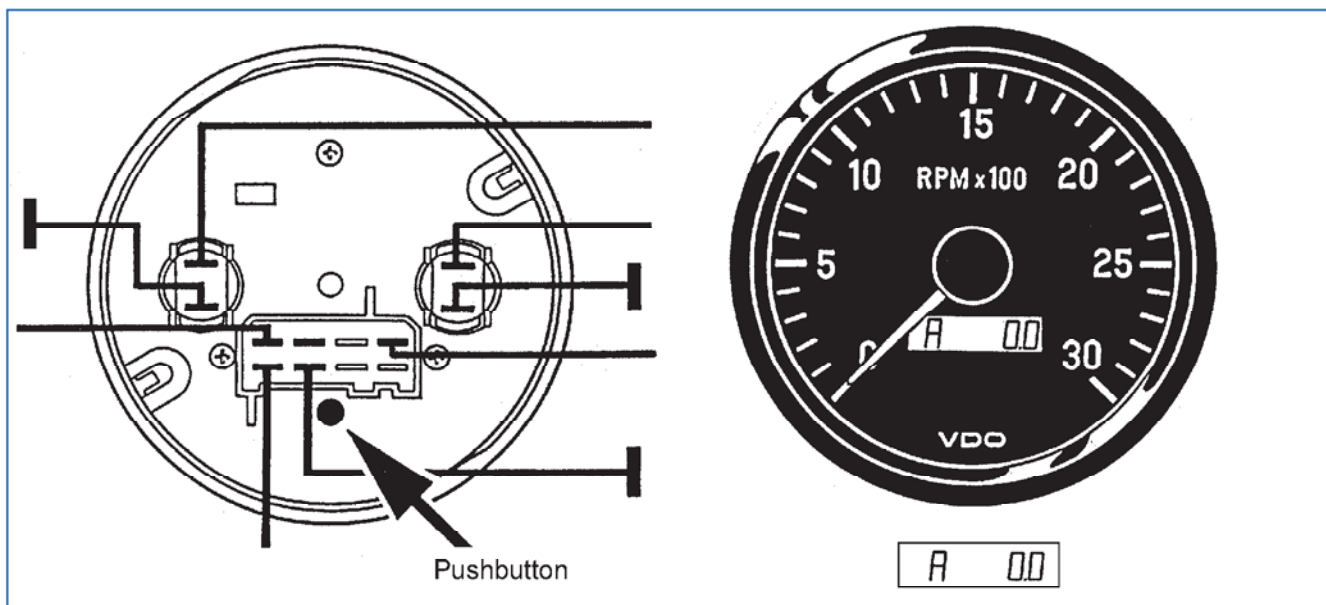

Switch ignition on, then push the button at the back of the instrument. The display shows 'A 0.0'.

4. Electronic Tachometer With Operating Hours Counter (dia. 80 mm / dia.100 mm) only for VDO cockpit international

4.5 Setting

Function 'SELECT'

After selection of the function 'SELECT' the display shows '4 - 8 C' (four-stroke, 8 cylinders) for instance after about 3 seconds.

Push the button in and hold. The display shows the possible settings for:

four-stroke, 1, 2, 3, 4, 5, 6, 8, 12 cylinders
(example: '4 - 8 C' = four-stroke, 8 cylinders),

two-stroke, 1, 2, 3, 4 cylinders
(example: '2 - 3 C' = two-stroke, 3 cylinders).

Release the pushbutton when the corresponding stroke and cylinder numbers are attained. The calibration is completed if the display thereafter changes to operating hours counter.

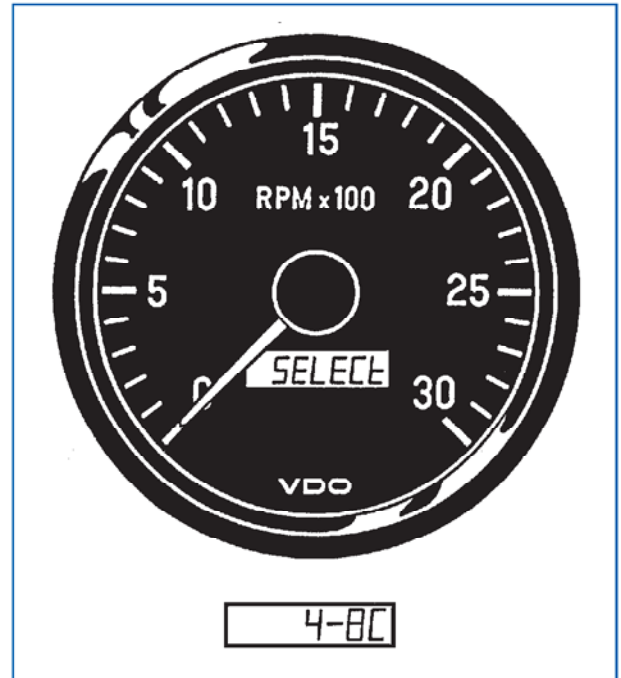

4. Electronic Tachometer With Operating Hours Counter (dia. 80 mm / dia.100 mm) only for VDO cockpit international

4.5 Setting

Function 'PULSE'

After selection of the function 'PULSE' the display shows 'P 14.50' for instance (14.50 pulses per revolution) after about three seconds, with the digit before the last flashing. Start entering the know pulse number per revolution. The flashing digit is changed by pushing the button (adjustable number of pulses revolution: 0.50 to 399.99). After entry of the number of pulses per revolution the display changes to operating hours counter mode. The calibration is completed.

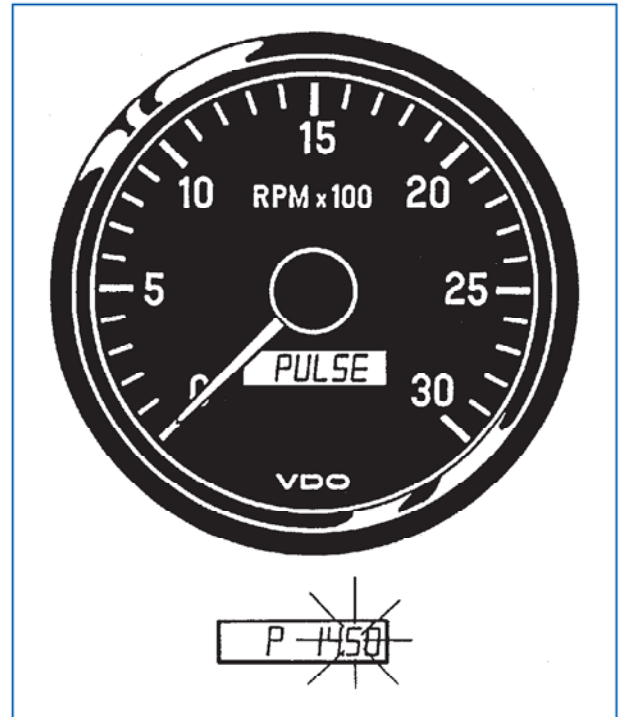

Selecting the function 'PULSE' again displays the entered number of pulses per revolution for checking. The display shows the number of pulses per revolution, and the last digits, starting with the digit, start flashing in a sequence.

The number of pulses per revolution can be calculated with following formula if it is not know:

Conventional ignition system:

$$\frac{\text{pulses}}{\text{revolution}} = \frac{2 \times \text{number of cylinders}}{\text{number of strokes} \times \text{number of ignition coils}}$$

↓
(two-stroke or four-stroke)

or it can be obtained from the engine manufacturer.

4. Electronic Tachometer With Operating Hours Counter (dia. 80 mm / dia.100 mm) only for VDO cockpit international

4.5 Setting

Function 'PULSE'

Diesel engine

The following formula can be used to calculate an unknown pulse ratio, which is then set described on page 4 - 12.

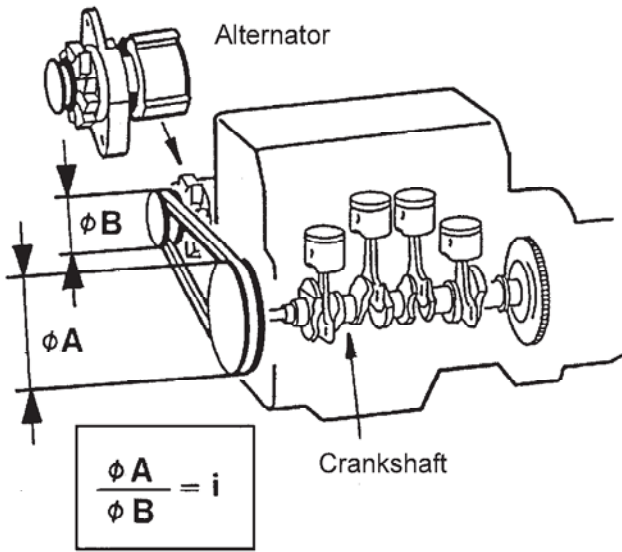

The diagram shows a cross-section of an engine with an alternator mounted on the front. The crankshaft is labeled 'Crankshaft' and the alternator is labeled 'Alternator'. Two diameters are indicated: ϕA for the crankshaft and ϕB for the alternator. A box contains the formula $\frac{\phi A}{\phi B} = i$.

Example:
 dia. A = 280 mm
 dia. B = 132 mm
 $i = \frac{280}{132} = 2.12$

$i \times 6 = \text{the pulse ratio}$

Pulses per revolution
 Number of alternator pole pairs
 $2.12 \times 6 = 12.72$
 = 13 pulses per revolution

Calculate the pulse ratio as follows if the frequency (Hz) is know, and not the pulse ratio:

Example 1733 Hz:

$$\frac{\text{Hz} \times 60 \text{ sec.}}{\text{full scale speed}} = \text{pulses per revolution}$$

$$\frac{1733 \times 60}{8000} = 12.99 = 13 \text{ pulses per revolution}$$

Formula for frequency (Hz):

$$\frac{\text{pulses per revolution} \times \text{full scale speed}}{60 \text{ sec.}} = \text{Hz}$$

Example:

$$\frac{13 \times 8000}{60} = 1733 \text{ Hz}$$

4. Electronic Tachometer With Operating Hours Counter (dia. 80 mm / dia.100 mm) only for VDO cockpit international

4.5 Setting

Function 'AdJUST' – fine adjustment of engine speed indication (continuous pointer adjustment)

This function permits fine engine speed indication adjustment between 30% and 100% of the indicating range only. Use a reference tachometer (hand-held tachometer) to compare the speed indications.

The adjustment must be made by two people, one of them adjusting the instrument, the other one using the hand-held tachometer.

Measure the engine speed at the crankshaft stub of the engine with the hand-held tachometer. Be very careful! Do not wear loose clothing!

The selection of function 'AdJUST' alternately displays 'UP' or 'dn' (down).

Holding the button down with the 'UP' display increments the pointer position (in the same way it will decrement if 'dn' is displayed). Initially the rate of change is quite low, permitting a very precise adjustment. Shortly releasing the button will repeat the process. The rate of pointer position change increases when the button is held down. Release the button when the pointer indication matches the reference indication. The display changes to operation hours count, fine adjustment is completed.

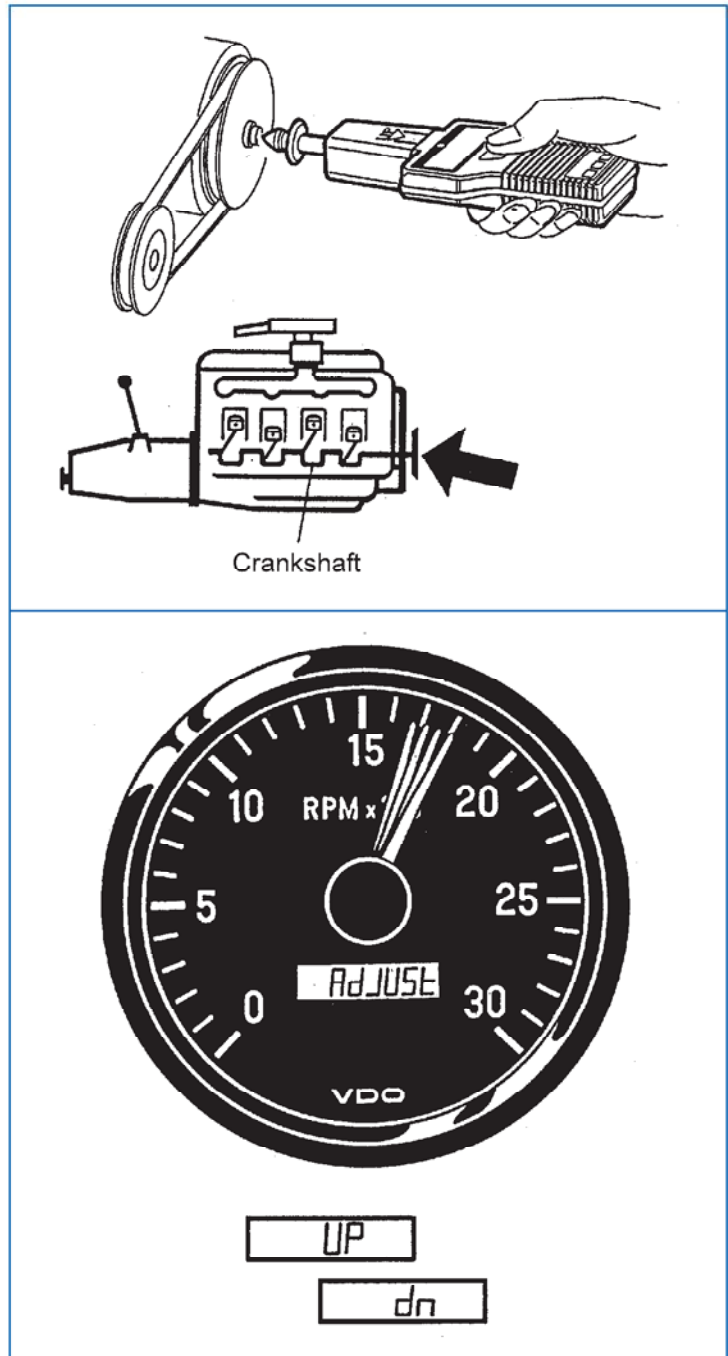

4. Electronic Tachometer With Operating Hours Counter (dia. 80 mm / dia.100 mm) only for VDO cockpit international

4.5 Setting

Function 'A' – fine adjustment of engine speed indication (pointer adjustment in percentage steps)

This function can be used for fine adjustment of the engine speed indication over the entire indicating range in angular steps of 0.5 degrees. Use a reference tachometer (hand-held tachometer) to compare the speed indications.

The display shows 'A 0.0' when the function 'A' is selected.

Push and hold the button to change the pointer deflection in a range of - 20 % to + 20 % in steps of 0.5 %.

These steps are shown by the display:

example in the plus range: 'A 10.5',

example in the minus range: 'A - 10.5'.

Plus and minus change if the pushbutton is briefly released.

Release the pushbutton when the desired percentage is attained. The display returns to the operating hours counter mode. Fine adjustment has been completed.

Calculation of the percentage value:

Find the difference between the tachometer display and the reference speed indication. Calculate the percentage and enter the corresponding value.

Percentage formula:

$$\pm \% = \frac{\text{difference between tachometer reading and reference reading}}{\text{tachometer reading}} \times 100$$

Example for the plus range:

tachometer reading = 1800 RPM
reference speed reading = 2000 RPM
difference = + 200 RPM

$$+ \% = \frac{200 \times 100}{1800} = + 11.11 \%$$

Percentage for fine adjustment: 'A 11.0'

Example for minus range:

tachometer reading = 2200 RPM
Reference speed reading = 2000 RPM
difference = - 200 RPM

$$- \% = \frac{200 \times 100}{2200} = - 9.09 \%$$

Percentage for fine adjustment: 'A - 9.0'

4. Electronic Tachometer With Operating Hours Counter (dia. 80 mm / dia.100 mm) only for VDO cockpit international

4.6 Display

Engine speed display

Tachometer **without** pin 5 (permanent positive pole 12 V/ 24 V)
Only produced before week 18/99.

Note:



When the ignition is switched off, the pointer remains at the last engine speed indicated, until the ignition is switched on again, without starting the engine, the pointer will then return to the zero position.

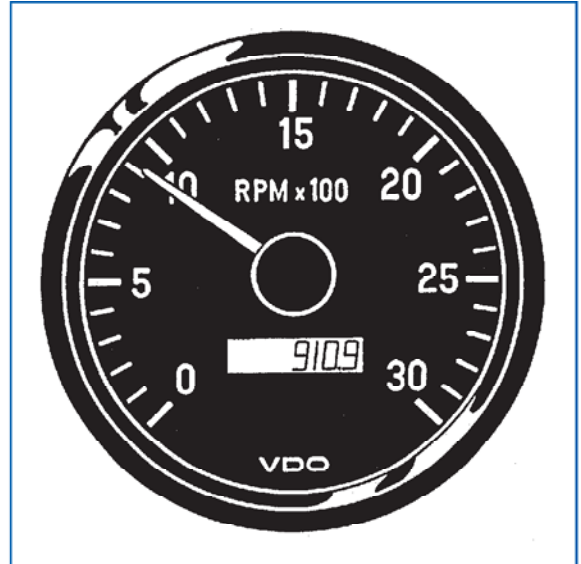

Tachometer **with** pin 5 (permanent positive pole 12 V/ 24 V)

Note:



When the ignition is switched off, the pointer will return to the zero position.
Then the instrument will automatically get turned off.

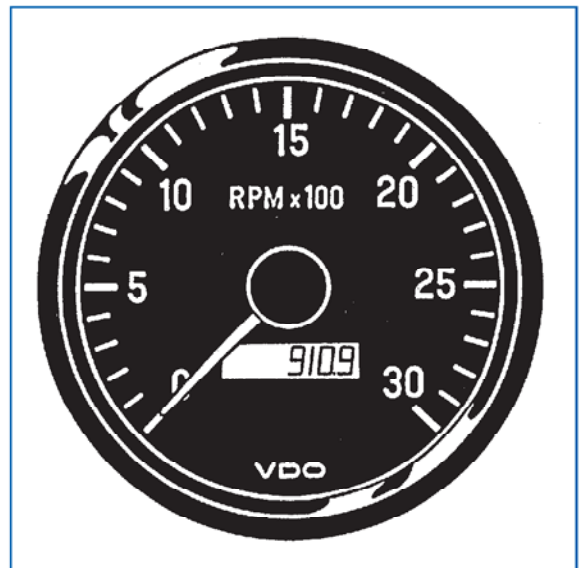

Operating hours display

The display shows operating hours up to '999999.9' max..
This display cannot be adjusted.

Operating hours remain stored after the operating voltage is switched off.

4. Electronic Tachometer With Operating Hours Counter (dia. 80 mm / dia.100 mm) only for VDO cockpit international

4.7 Testing Instructions

- Test accessories**
- 1x Power supply
 - 1x Test cable No. 2 } contained in test cables kit
 - 1x Measuring cable } X12.019/101/001
 - 1x Frequency generator
 - 1x Ammeter
 - 1x Wire for pin 5 of the test cable No. 2 (see chapter 18.2.5)

Connector pin allocation

1	2	3	4
5	6	7	8

- Pin 3 Ground
- Pin 4 +10 V to + 31 V
- Pin 5* Permanent positive pole 12 V / 24 V
- Pin 8 Sensor signal input

Test circuit diagram

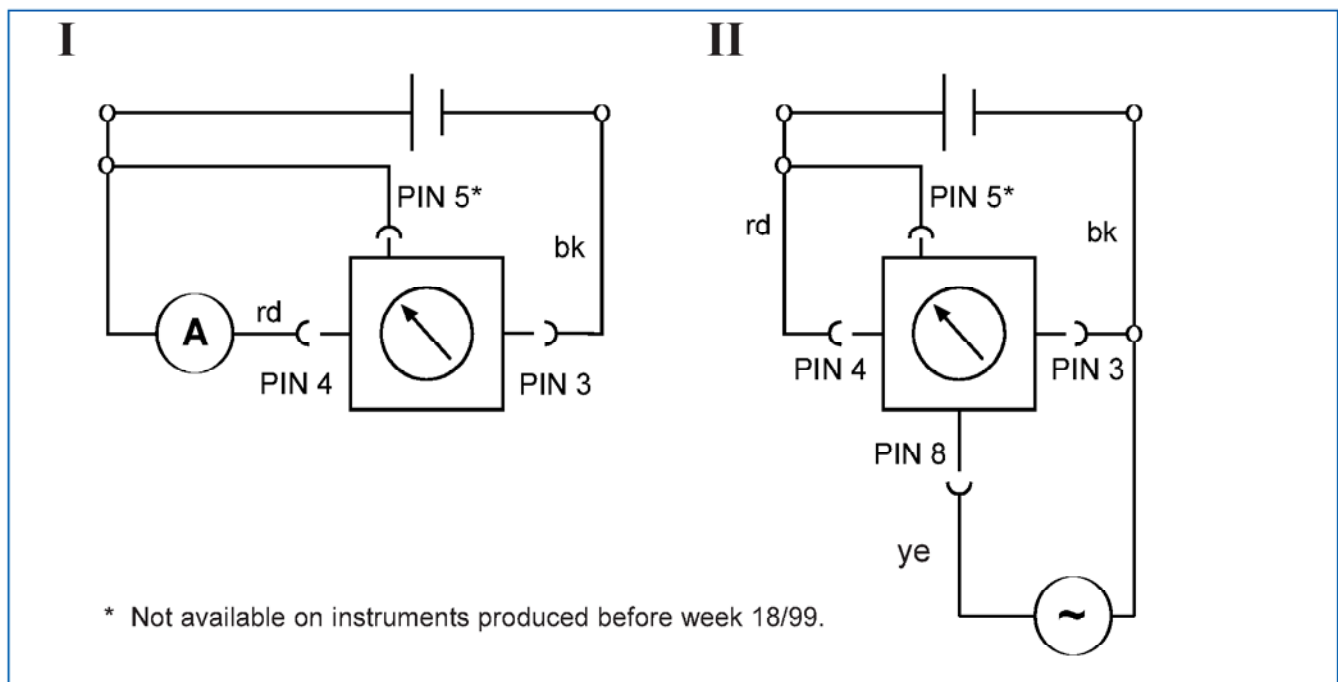

Test method description

Basic setting:	12 V to 24 V instruments	»»»»	U = 18 V ± 2 V
	strokes + cylinders	»»»»	4 - 4 C
	function 'A'	»»»»	A 0.0

Current consumption measurement

Connect the instrument per test circuit diagram II with test cable No. 2.

Value range: 12V to 24 V instruments »»»» I = 52 ± 5.2 mA

4. Electronic Tachometer With Operating Hours Counter (dia. 80 mm / dia.100 mm) only for VDO cockpit international

4.7 Testing Instructions

Operating hours counter test

Connect instrument with test cable No. 2 as shown in test circuit diagram II.

After connection of the operating voltage the display shows the operating hours. After connection of the engine speed signal of the operating hours are counted and the engine speed is displayed.

The comma flashes with a 1Hz frequency at speeds exceeding 400 rpm.



It is only possible to reset the operating hours with software (see chapter 18.2.6).

Pointer position test

a) Zero point test

Connect instrument with test cable No. 2 as shown in test circuit diagram I.

Connect the operating voltage and check pointer deviation. The allowed deviation is ± 1 degree of angle.

b) Full scale indication test

Connect instrument with test cable No. 2 as shown in test circuit diagram II.

Connect a square wave signal to connector pin 4. The frequency can be calculated with the following formula, the amplitude being between 1 V and 10 V.

Formula for number of pulses per revolution:

$$\left(\frac{\text{pulses}}{\text{revolution}} \right) = \frac{2 \times \text{number of cylinders}}{\text{stroke type} \times \text{number of ignition coil}}$$

Formula for the frequency:

$$f_{\max} = \frac{\left(\frac{\text{pulses}}{\text{revolution}} \right) \times \text{full-scale value}}{60} \text{ [Hz]}$$

Example:

Tachometer with 3000 rpm full-scale, 4 cylinders, four-stroke, 1 ignition coil.

$$\frac{\text{pulses}}{\text{revolution}} = \frac{2 \times 4}{4 \times 1} = 2$$

$$f_{\max} = \frac{2 \times 3000}{60} = 100 \text{ Hz}$$

4. Electronic Tachometer With Operating Hours Counter (dia. 80 mm / dia.100 mm) only for VDO cockpit international

4.8 Instruments Survey

VDO cockpit international (Floodlight) dia. 80 mm

Part No. 333 035 . . .

Dial		Special feature	Part No.
Range	Imprint		
0 ... 3000 min ⁻¹	RPM x 100	12 V - 24 V, dia. 80 mm 12 V illumination	010 C 010 G
0 ... 4000 min ⁻¹	RPM x 100	12 V - 24 V, dia. 80 mm 12 V illumination	011 C 011 G
0 ... 6000 min ⁻¹	RPM x 100	12 V - 24 V, dia. 80 mm 12 V ill., with warning contact	014 C

VDO cockpit international (Floodlight) dia. 100 mm

Part No. 333 055 . . .

Dial		Special feature	Part No.
Range	Imprint		
0 ... 3000 min ⁻¹	RPM x 100	12 V - 24 V, dia.100 mm 12 V illumination	002 C 002 G
0 ... 3000 min ⁻¹	RPM x 100 23 - 30 red warning field	12 V - 24 V, dia.100 mm 24 V illumination	004 C
0 ... 3000 min ⁻¹	RPM x 100 25 - 30 red warning field	12 V - 24 V, dia.100 mm 24 V illumination	010 C

4. Electronic Tachometer With Operating Hours Counter (dia. 80 mm / dia.100 mm) only for VDO cockpit international

4.9 Installation Instructions

999 165 009: VDO cockpit international

See file 'Installation Instructions'. ▼

▼ will follow